

Weitergabe sowie Vervielfältigung dieses Dokuments, Verwertung und Mitteilung seines Inhalts sind verboten, soweit nicht ausdrücklich gestattet. Zuwiderhandlungen verpflichten zu Schadensersatz. Alle Rechte für den Fall der Patent-, Gebrauchsmuster- oder Geschmacksmusterreinertragung vorbehalten. © Pfisterer

The reproduction, distribution and utilization of this document as well as the communication of its contents to others without explicit authorization is prohibited. Offenders will be held liable for the payment of damages. All rights reserved in the event of the grant of a patent, utility model or design. © Pfisterer

Var. 101 - 112
(Ohne Schutzkappe / without protective cap)

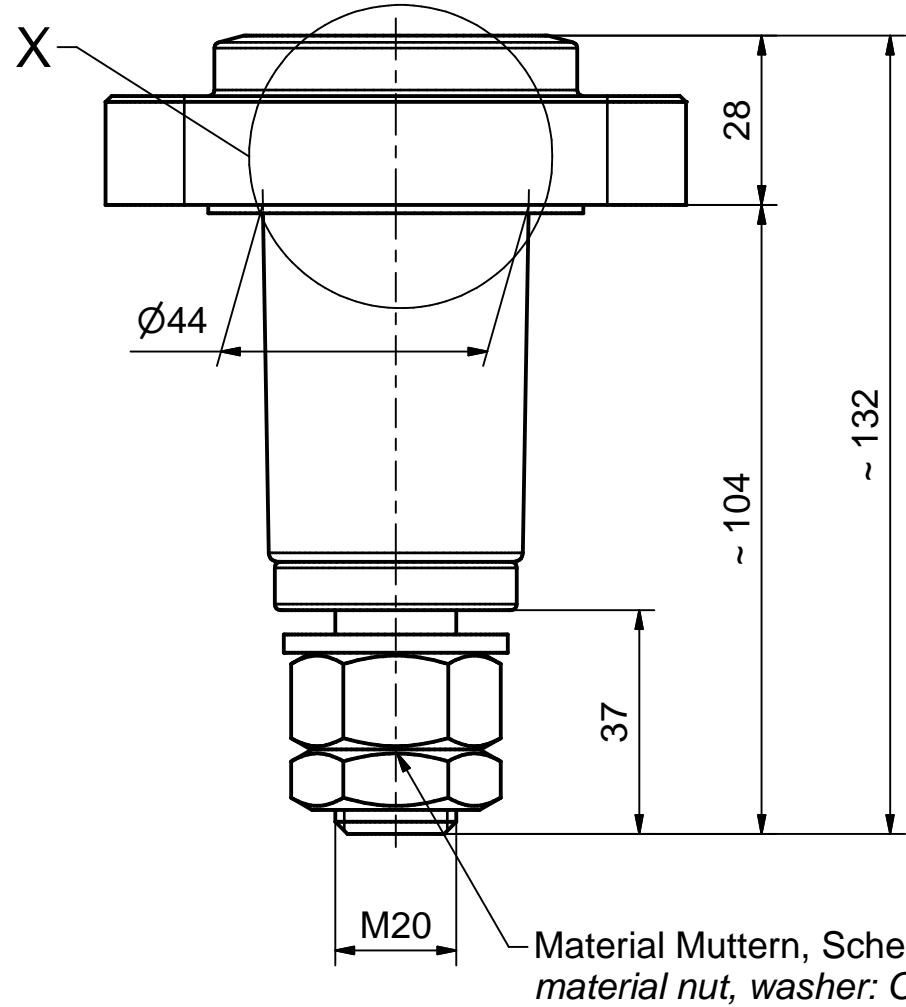

Material Muttern, Scheibe: CuZn
material nut, washer: CuZn

Var. 301 - 312
(Ohne Schutzkappe / without protective cap)

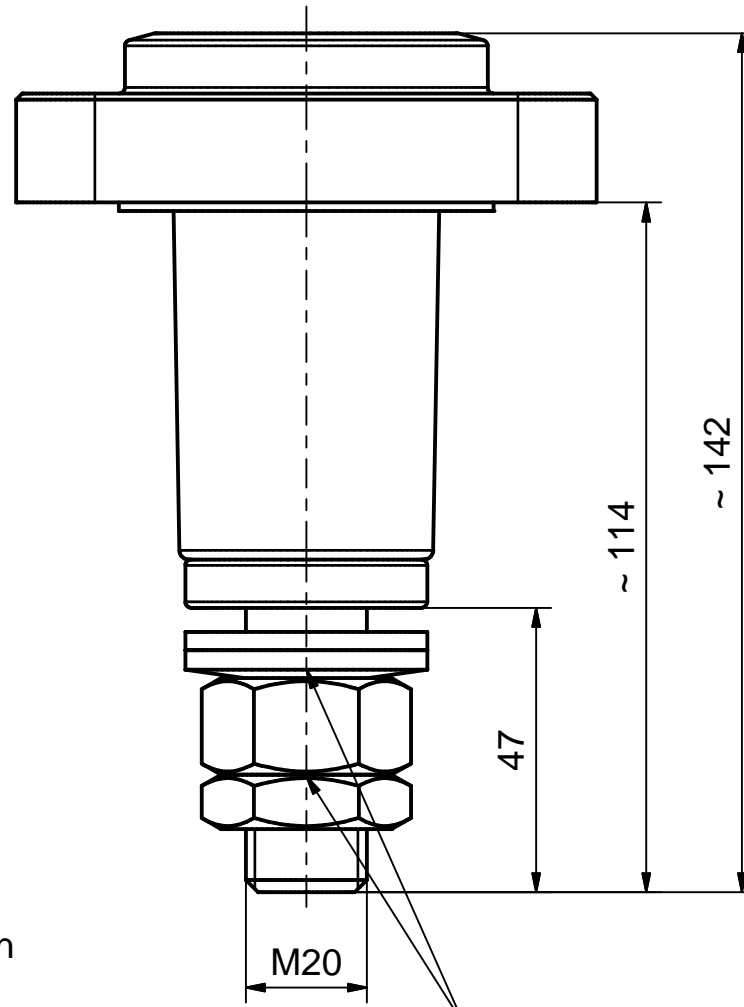

Material Muttern, Scheibe: A2
und zusätzliche Sicherungsscheibe
material nut, washer: A2
with additional sprin washer

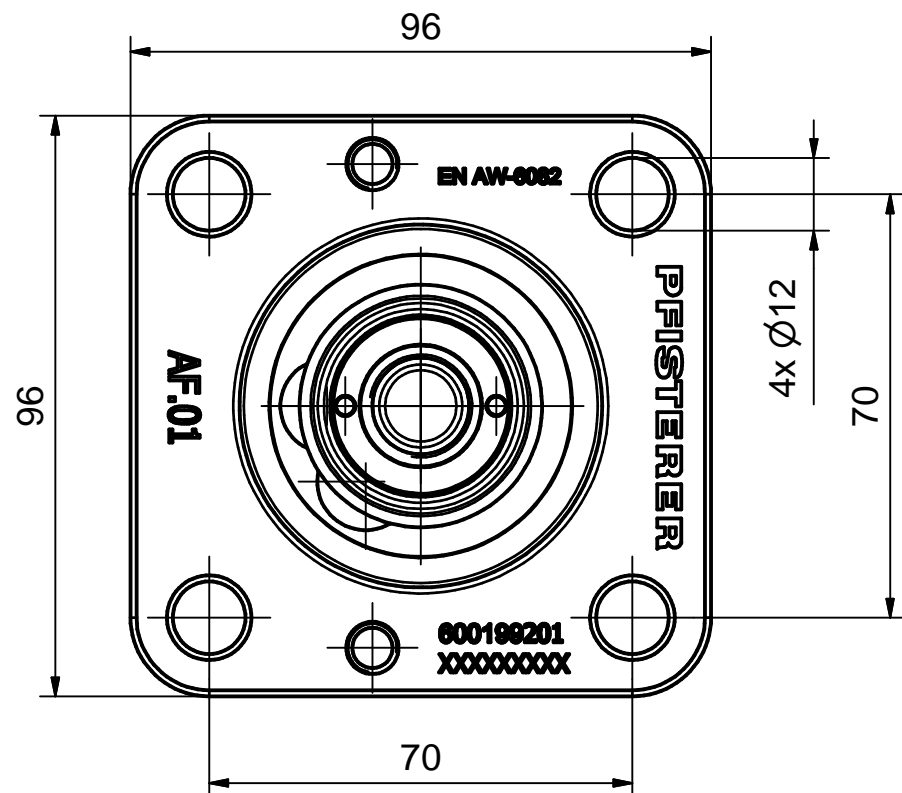
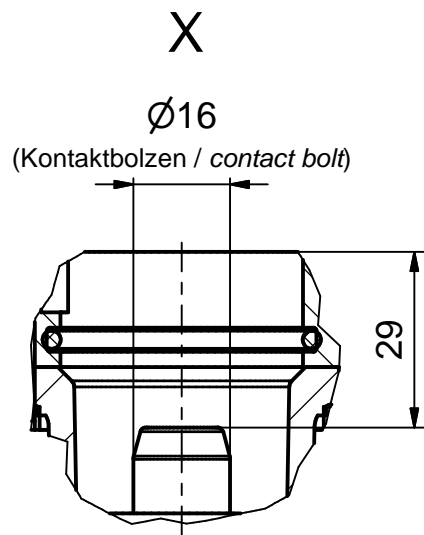

Var. 305007101

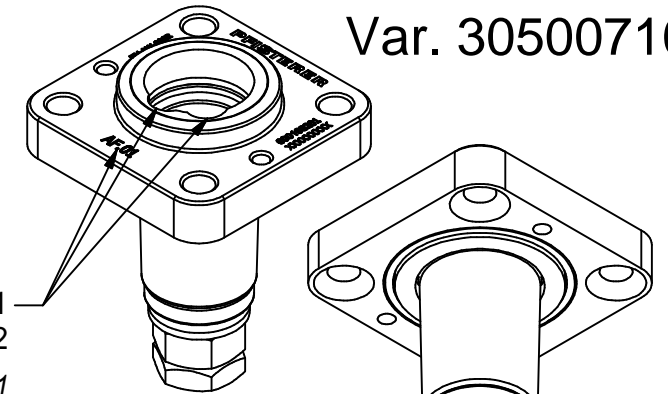

Kodierungsbeispiel AF01
Kodierung AF01 - AF12
coding example AF01
coding AF01 - AF12

Anzugsdrehmoment: MA = 40 Nm
torque specification: MA = 40 Nm

AF.12	305 007	312
AF.11	305 007	311
AF.10	305 007	310
AF.09	305 007	309
AF.08	305 007	308
AF.07	305 007	307
AF.06	305 007	306
AF.05	305 007	305
AF.04	305 007	304
AF.03	305 007	303
AF.02	305 007	302
AF.01	305 007	301
AF.12	305 007	112
AF.11	305 007	111
AF.10	305 007	110
AF.09	305 007	109
AF.08	305 007	108
AF.07	305 007	107
AF.06	305 007	106
AF.05	305 007	105
AF.04	305 007	104
AF.03	305 007	103
AF.02	305 007	102
AF.01	305 007	101
Kodierung	Stammnr.	Var.
	Artikelnummer	

Maßstab / scale 1:1,25	Gewicht ca. / weight ca. (g)	Beschreibung / title P3 Einbaubuchse (P3PS) P3 panel socket (P3PS)			
Erstellt von / created by Fragner	Datum / date 2008-03-18				
Geprüft von / approved by Fragner	Datum / date 2008-03-18				
PFISTERER PFISTERER Kontaktsysteme GmbH Germany		Ersatz für / replacement for Für Kunden	Dokumentart / type of document Für Kunden	Dateiname / filename S03-131419	Format / size A3
Änd.nr. / rev. no. 20200957	Änd.datum / date of issue 2020-07-09	Name / name Fragner	Index / rev. 05	Dokumentnr. / document no. 305007A	Blatt / sh. 1/1