

Weitergabe sowie Vervielfältigung dieses Dokuments, Verwertung und Mitteilung seines Inhalts sind verboten, soweit nicht ausdrücklich gestattet. Zuwiderhandlungen verpflichten zu Schadensersatz. Alle Rechte für den Fall der Patent-, Gebrauchsmuster- oder Geschmacksustereintragung vorbehalten. © Pfisterer

The reproduction, distribution and utilization of this document as well as the communication of its contents to others without explicit authorization is prohibited. Offenders will be held liable for the payment of damages. All rights reserved in the event of the grant of a patent, utility model or design. © Pfisterer

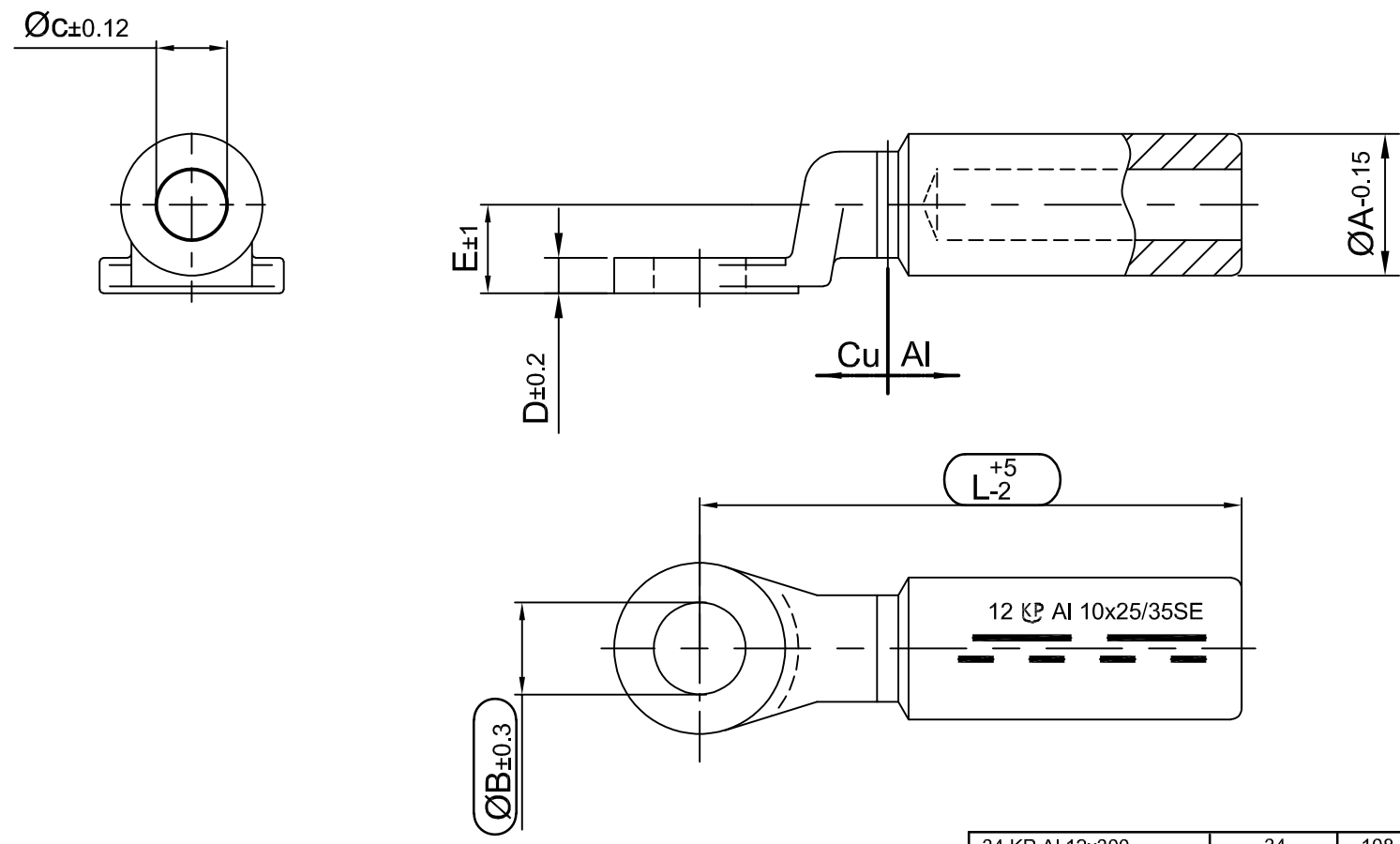

34 KP Al 12x300	34	108	19	7	13.0	34	23.3	247	8	8	3	305668	028
32 KP Al 12x240/300SE	32	108	19	7	13.0	32	21	233	7	8	3	305668	025
28 KP Al 16x185/240SE	28	98	19	7	17.0	28.5	18.3	200	5	6	3	305668	023
28 KP Al 12x185/240SE	28	98	19	7	13.0	28.5	18.3	204	5	6	3	305668	022
25 KP Al 16x150/185SE	25	101	19	7	17.0	25	16.3	125	5	6	3	305668	020
25 KP Al 12x150/185SE	25	101	19	7	13.0	25	16.3	132	5	6	3	305668	019
22 KP Al 12x120/150SE	22	92	15	6	13.0	23	14.7	127	4	6	3	305668	016
22 KP Al 16x95/120SE	22	91	15	6	17.0	22	13.2	115	3	6	3	305668	015
22 KP Al 12x95/120SE	22	91	15	6	13.0	22	13.2	127	3	6	3	305668	014
22 KP Al 10x95/120SE	22	91	15	6	10.5	22	13.2	128	3	6	3	305668	013
18 KP Al 12x70/95SE	18	82.5	12	6	13.0	18.5	11.2	73	3	6	3	305668	011
16 KP Al 12x50/70SE	16	72.5	12	6	13.0	16	9.8	60	2	5	2	305668	008
16 KP Al 10x50/70SE	16	72.5	12	6	10.5	16	9.8	61	2	5	2	305668	007
14 KP Al 12x35/50SE	14	75	12	6	13.0	14	8	36	1	5	2	305668	005
14 KP Al 10x35/50SE	14	75	12	6	10.5	14	8	37	1	5	2	305668	004
12 KP Al 10x25/35SE	12	63	12	6	10.5	12	6.8	33	1	4	2	305668	002

Leiterquerschnitt SM/RM mm <sup>2</sup>	Werkzeugkennzahl nach DIN 48083 Teil 4	L	E	D	øB	øA	øc	Presskabelschuh	Fett	mech. / hydr. Anzahl d.Pressmarkierung pro Seite	Artikelnr.	Variante
conductor cross section SM/RM mm <sup>2</sup>	tool code according to DIN 48083 part 4	Länge						Gewicht / Gramm		mech. / hydr. number of compression marks per side	item number	type
		L Length						compression cable lug weight / gramm				

Maßstab / scale <b>1:1</b>		Gewicht ca. / weight ca. (-)			
Name / name Guata		Datum / date 17.10.2022		Beschreibung / title <b>Presskabelschuh Al/Cu längsdicht</b>	
Erstellt von created by		Geprüft von approved by		Compressed Cable Lug Al/Cu Longitudinally sealed	
Pfisterer		Pfisterer		-	
<b>PFISTERER</b>		Ersatz für / replacement for		Dokumentart / type of document Kundenzeichnung / Customer drawing	
PFISTERER Kontaktsysteme GmbH Germany		Änd.nr. / rev. no. 20223060		Status / status Serienfreigabe / Series Release	
		Index / rev. 02		Dateiname / filename 100000000021527_drw_000.dwg	
				Format / size A3	
				Blatt / sh. 1/1	
				PFISTERER Dokumentnr. / PFISTERER document no. <b>305668A</b>	