

Weitergabe sowie Vervielfältigung dieses Dokuments, Verwertung und Mitteilung seines Inhalts sind verboten, soweit nicht ausdrücklich gestattet. Zuwiderhandlungen verpflichten zu Schadensersatz. Alle Rechte für den Fall der Patent-, Gebrauchsmuster- oder Geschmacksustereintragung vorbehalten. © Pfisterer

The reproduction, distribution and utilization of this document as well as the communication of its contents to others without explicit authorization is prohibited. Offenders will be held liable for the payment of damages. All rights reserved in the event of the grant of a patent, utility model or design. © Pfisterer

Druckschraube M26x1,5 SW8
pressure screw M26x1,5
width across flats 8

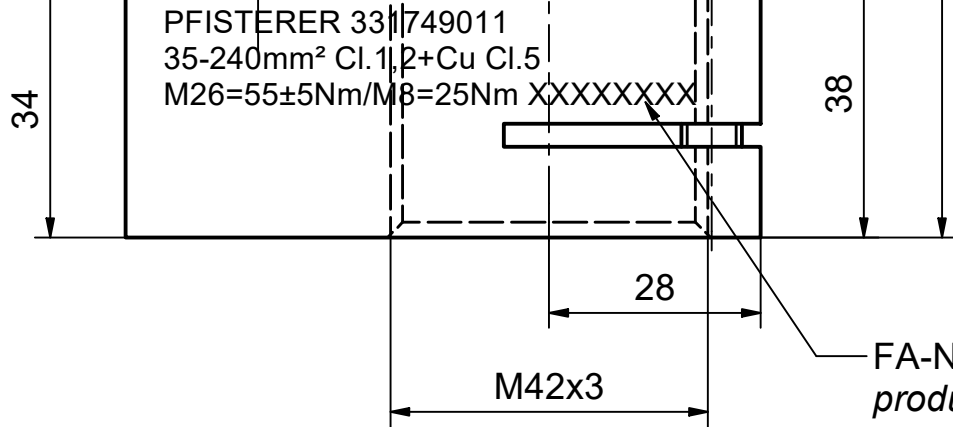

FA-Nummer
production order number

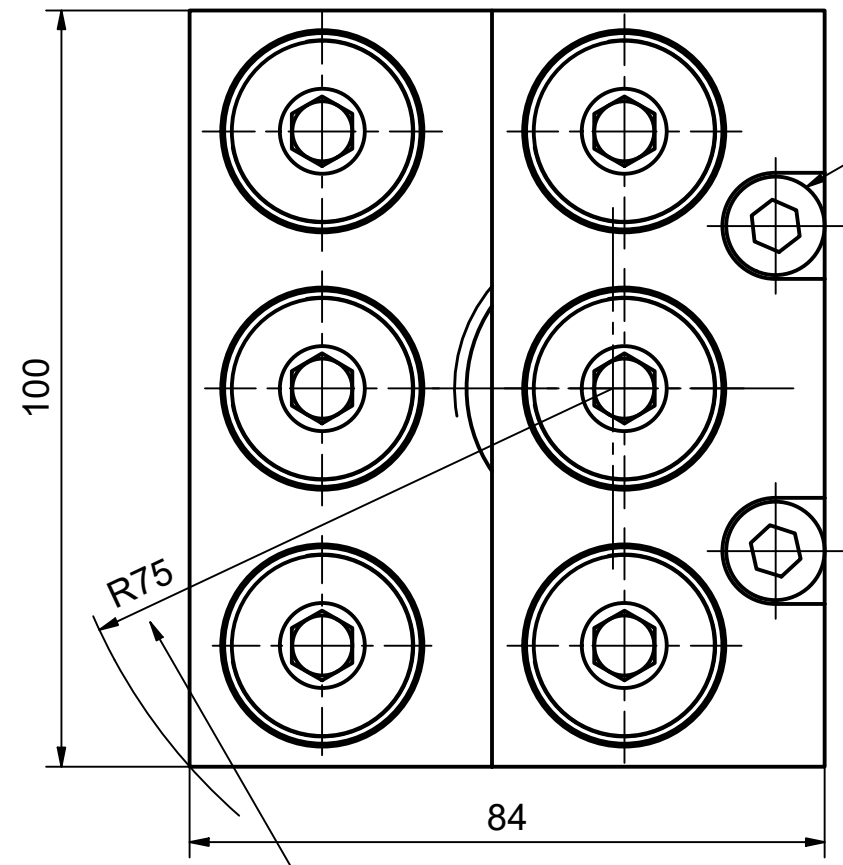
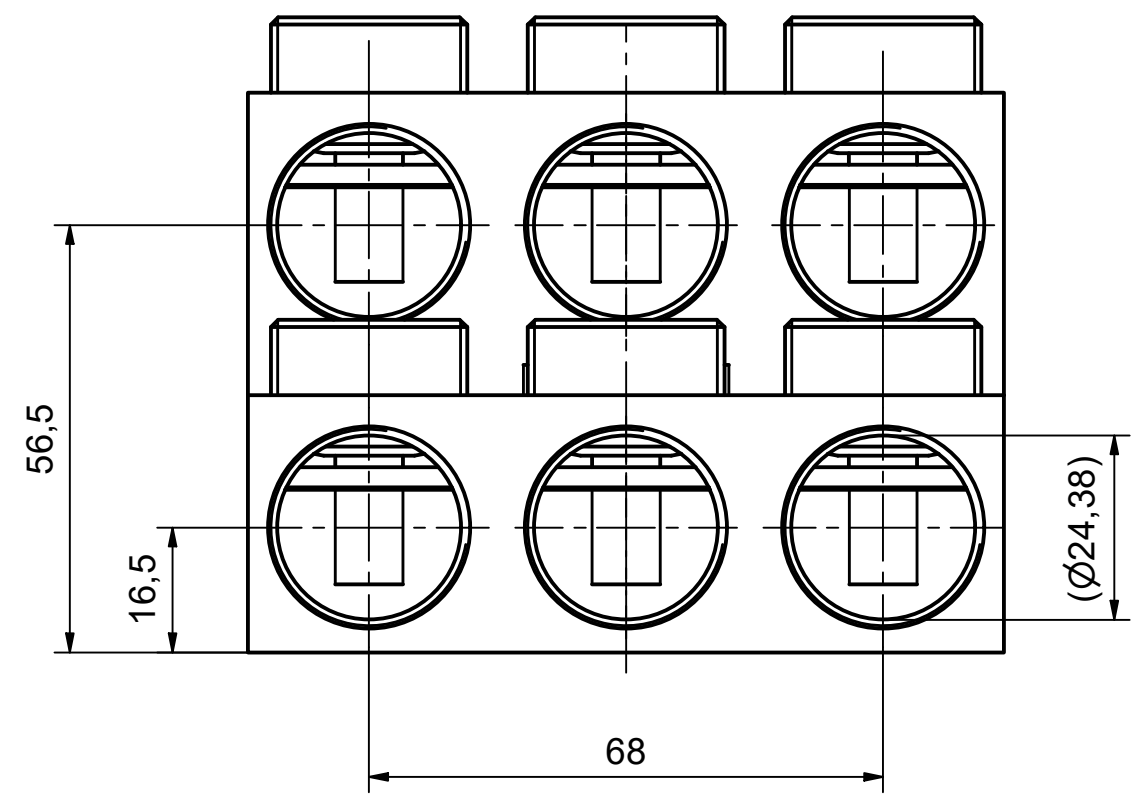

Zylinderschraube M8, SW6
hexagon socket head cap screw M8,
width across flats 6

umschriebener Kreis
circumscribed diameter

(1:2)

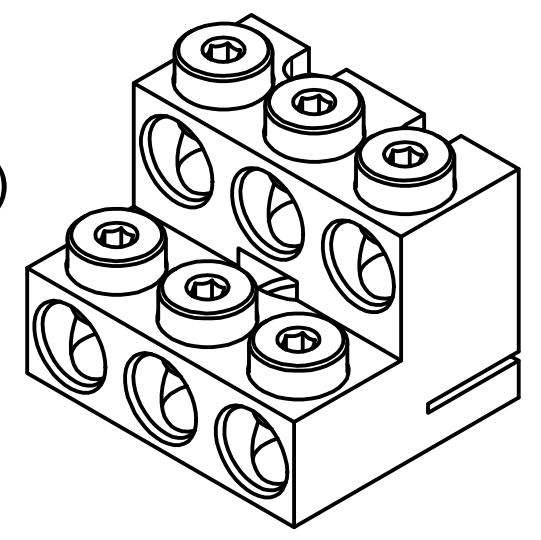

Min. erforderlicher Polmittenabstand 108 mm.
Min. required pole center distance 108 mm.

Maßstab / scale 1:1	Gewicht ca. / weight ca. (KG) 1,25	Beschreibung / title 2DIREKT Trafoanschlussklemme 1kV, 6x35-240 mm ² f. Durchführung M42x3, L84xB100xH74			
Erstellt von / created by SCHEIERM	Datum / date 17.01.2024	2DIREKT transformer clamp 1kV, 6x35-240 mm ² for terminal M42x3, L84xB100xH74			
Geprüft von / approved by JAEGERT	Datum / date 17.01.2024	Ersatz für / replacement for	Dokumentart / type of document Kundenzeichnung / Customer drawing	Dateiname / filename 100000000103842_DRW_000.IDW	Format / size A3
PFISTERER PFISTERER Kontaktsysteme GmbH Germany		And.nr. / rev. no. 20240229	Status / status Serienfreigabe / Series Release	Index / rev. 03	Blatt / sh. 1/1
					PFISTERER Dokumentnr. / PFISTERER document no. 331749011A