

Weitergabe sowie Vervielfältigung dieses Dokuments, Verwertung und Mitteilung seines Inhalts sind verboten, soweit nicht ausdrücklich gestattet. Zuwiderhandlungen verpflichten zu Schadensersatz. Alle Rechte für den Fall der Patent-, Gebrauchsmuster- oder Geschmacksustereinträgung vorbehalten. © Pfisterer

The reproduction, distribution and utilization of this document as well as the communication of its contents to others without explicit authorization is prohibited. Offenders will be held liable for the payment of damages. All rights reserved in the event of the grant of a patent, utility model or design. © Pfisterer

1 2 3 4

A

A-A

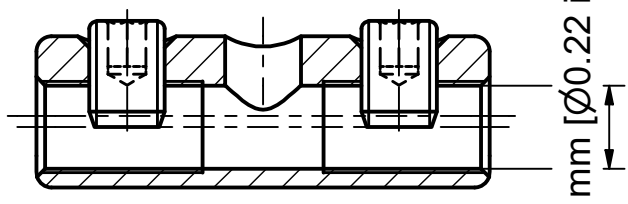

Ø5,5 mm [Ø0.22 in]

B

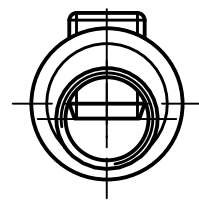
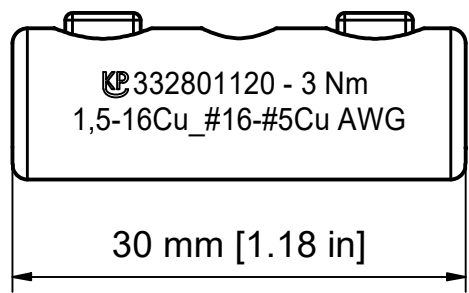

C

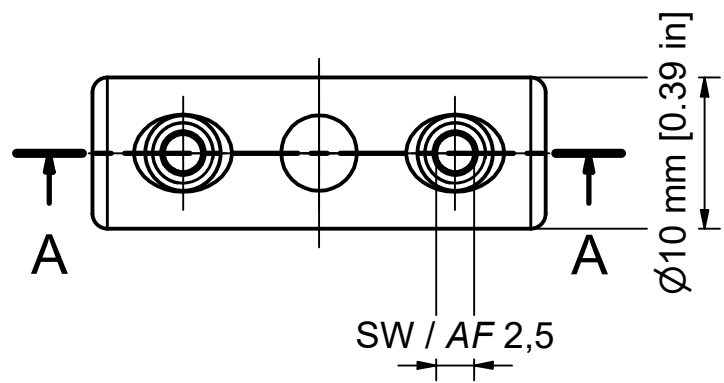

D

Je 4 Stück in PE-Beutel verpackt. /
4 pieces packed into PE bag.
Anzugsmoment 3 Nm /
Tightening torque 3 Nm

E

Maßstab / scale 2 : 1		Gewicht ca. / weight ca. (G) 13					
Erstellt von / created by BANZHAFM		Datum / date 09.10.2023		Beschreibung / title 1kV-Schraubverbinder_Sichtloch/2 Stiftschrauben 1,5-16Cu mm ² #16-#5Cu AWG_ø10xL30/ø5,5_3Nm, Ms, blank			
Geprüft von / approved by GROEZINGER		Datum / date 09.10.2023		Beschreibung / title 1kV-Bolted Connector Inspec. hole/2 bolts 1,5-16Cu mm ² #16-#5Cu AWG_ø10xL30/ø5,5_3Nm, CuZn, bare			
PFISTERER PFISTERER Kontaktsysteme GmbH Germany				Ersatz für / replacement for		Dokumentart / type of document Kundenzeichnung / Customer drawing	
				Änd.nr. / rev. no. 20231596		Status / status Serienfreigabe / Series Release	
				Dateiname / filename 10000032933_drw_000.IDW		Format / size Blatt / sh. A4 1/1	
				Index / rev. 02		PFISTERER Dokumentnr. / PFISTERER document no. 332801120AI	

F

A

B

C

D

E

F

1 2 3 4