

Weiergabe sowie Vervielfältigung dieses Dokuments, Verrentung und Mitteilug seines Inhalts sind verboten, soweit nicht ausdrücklich gestattet. Zuwiderhandlungen verpflichten zu Schadensersatz. Alle Rechte für den Fall der Patent-, Gebrauchsmuster- oder Geschmacksenerreinerung vorbehalten. © Pfisterer

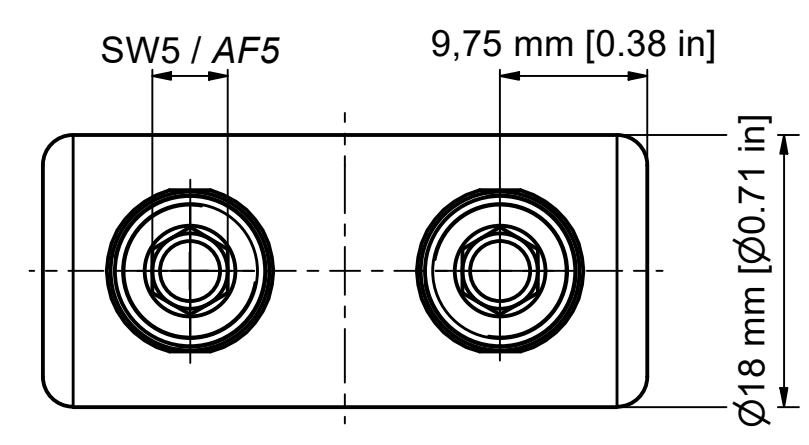
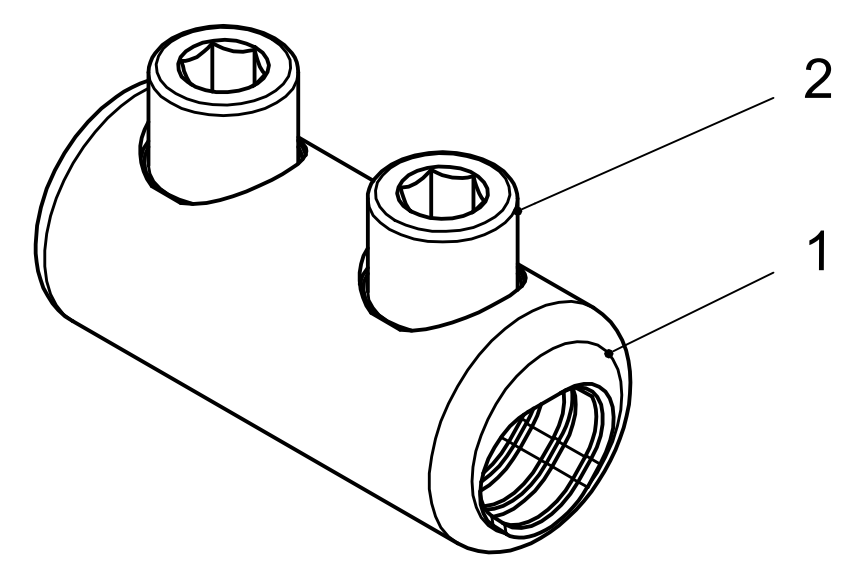
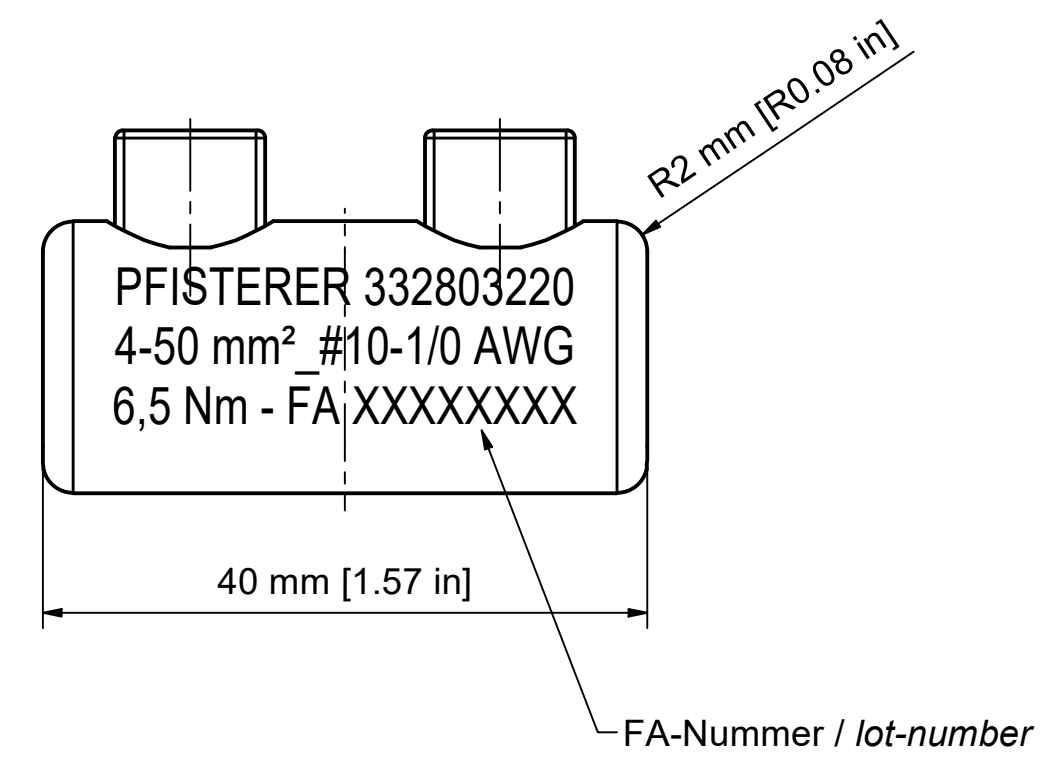
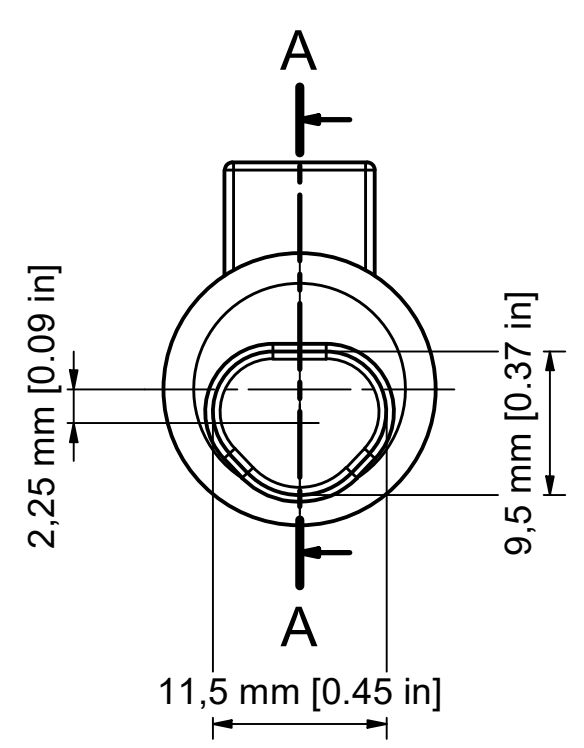
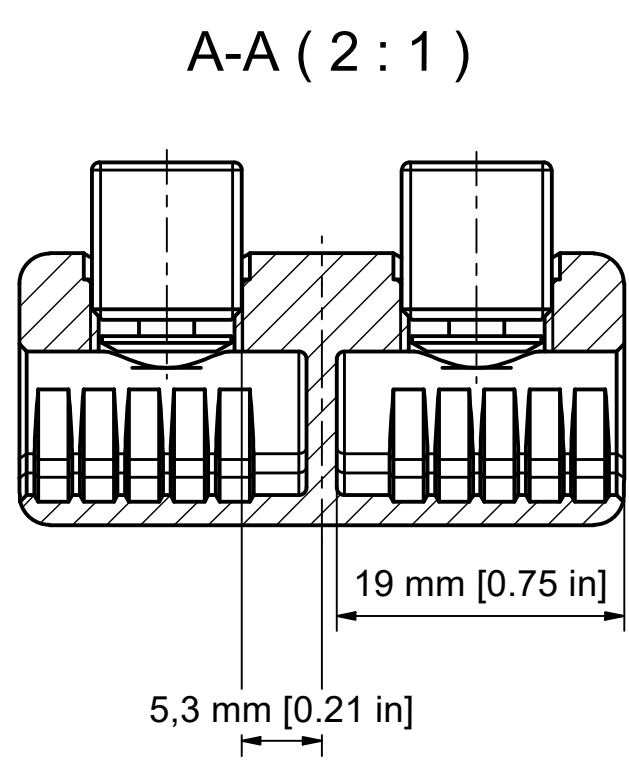

SM 120° / sector stranded 120°		35 - 50		35 - 50	
SE 120° / sector solid 120°		50			
SM 90° / sector stranded 90°		35 - 50		35 - 50	
SE 90° / sector solid 90°		50			
RE / round solid		4 - 50 (Ø 2,3-7,8)	#10 - 1/0 [Ø 0.10"-0.33"]	4 - 50 (Ø 2,3-7,8)	#10 - 1/0 [Ø 0.10"-0.33"]
RMV / round stranded and compressed		10 - 50 (Ø 3,6-8,6)	#8 - 1/0 [Ø 0.14"-0.37"]	10 - 50 (Ø 3,6-8,6)	#8 - 1/0 [Ø 0.14"-0.37"]
RM / round stranded		10 - 50 (Ø 3,7-9,1)	#8 - 1/0 [Ø 0.14"-0.37"]	10 - 50 (Ø 3,7-9,1)	#8 - 1/0 [Ø 0.14"-0.37"]
Einheit / unit		mm² (mm)	AWG / kcmil [inch]	mm² (mm)	AWG / kcmil [inch]
Norm / standard		DIN EN 60228	NEMA WC 70/71/74	DIN EN 60228	NEMA WC 70/71/74
Leiterarten / conductor type		Querschnittsbereich Aluleiter / cross section aluminium conductor		Querschnittsbereich Kupferleiter / cross section copper conductor	

Stückliste / BOM					
OBJEKT	ANZAHL	BEZEICHNUNG			
1	1	Körper LV-MC_OS_4-50_40x18/11,5x9,5, verzinkt Body LV-MC_OS_4-50_40x18/11,5x9,5, tinned			
2	2	LV-Stiftschraube SG10x1, Alu blank / LV-Grub screw SG10x1, aluminum uncoated			
Maßstab / scale		Gewicht ca. / weight ca. (G)			
2 : 1		19			
	Name / name	Datum / date	Beschreibung / title		
Erstellt von / created by	BANZHAFM	19.10.2023	1kV-Schraubverbinder - Trennsteg/2 Stiftschrauben 4-50mm² #10-1/0 AWG_ø18xL40/11,5x9,5_6,5Nm_Al, verzinkt		
Geprüft von / approved by	GROEZINGER	11.01.2024	1kV-Bolted Connector - Oil stop/2 grub screws 4-50mm² #10-1/0 AWG_ø18xL40/11,5x9,5_6,5Nm_Al, tinned		
PFISTERER		Ersatz für / replacement for		Dokumentart / type of document	
PFISTERER Kontaktsysteme GmbH Germany		T00256-BA-03A1		Kundenzzeichnung / Customer drawing	
20232777		Status / status		Index / rev.	
Serienfreigabe / Series Release		02		Dateiname / filename 1000022872_drw_000.iwr	
332803220A1		1/1		Format / size A2	