

Muttern wechselseitig zuerst mit einem Drehmoment von 20 Nm und anschließend mit 35 Nm anziehen.

*Tighten the nuts alternating at first with a torque of 20 Nm and following with 35 Nm*

- \* 1 St. Flanschring  
1 pc flange ring
- \* 4 St. Druckstück  
4 pcs thrust piece

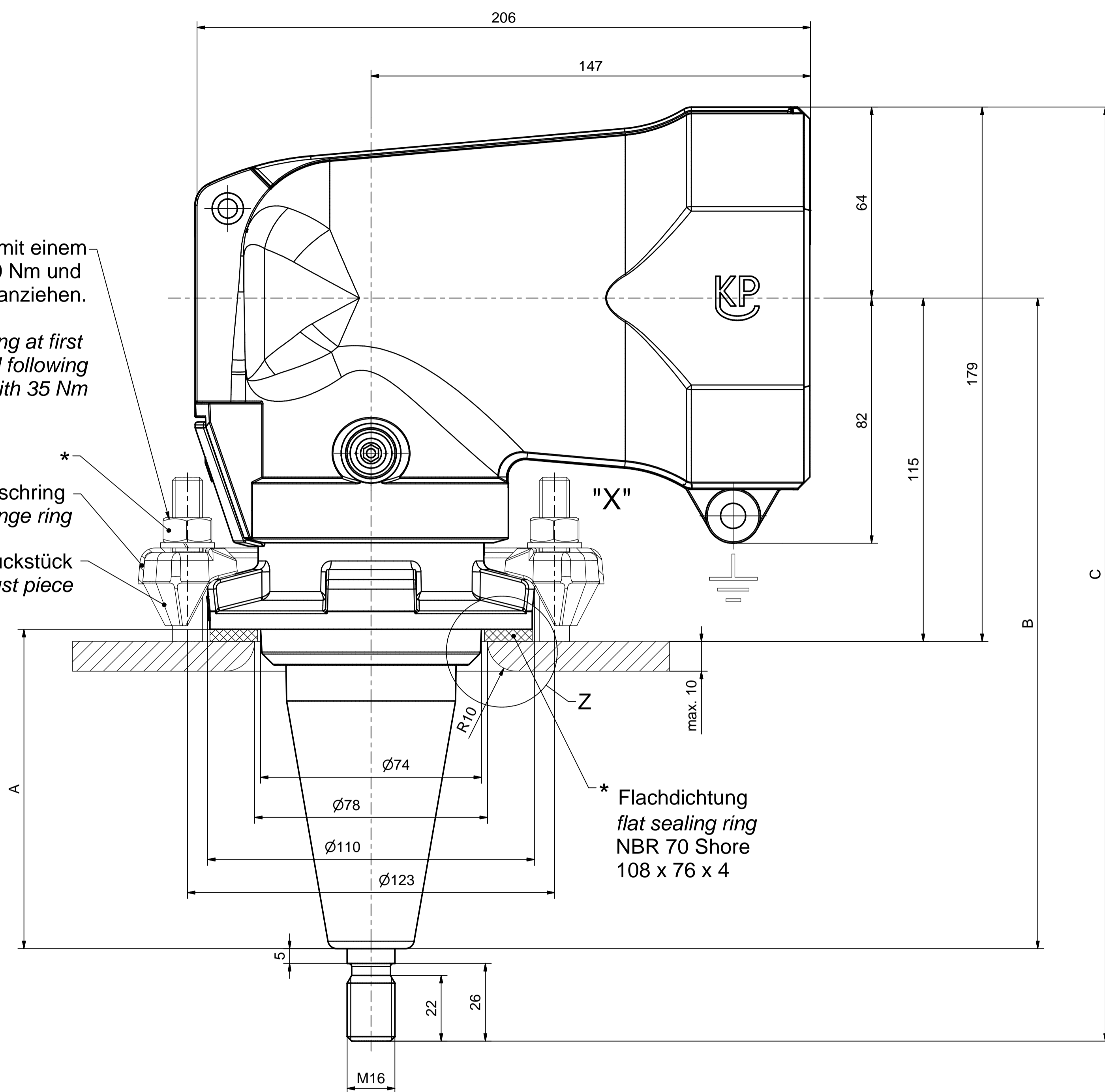

Alternativer Flansch  
alternative flange

Befestigung nach DIN 42538 Flansch A  
Fastening in accordance with DIN 42538 flange A

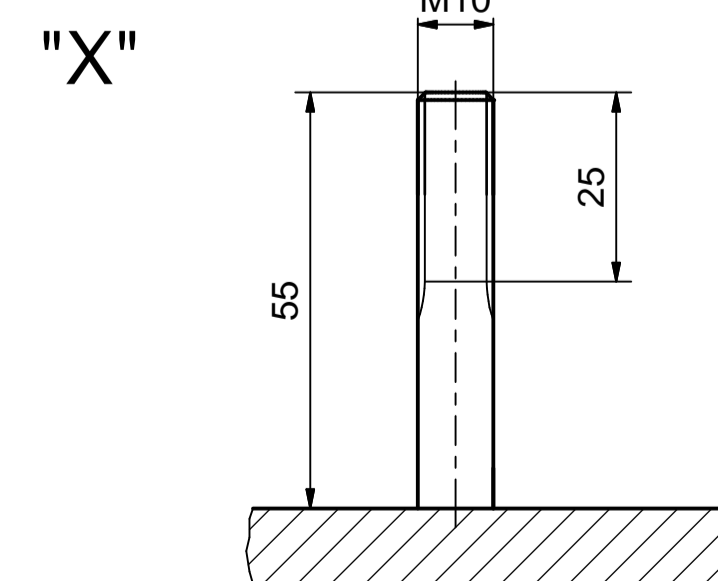
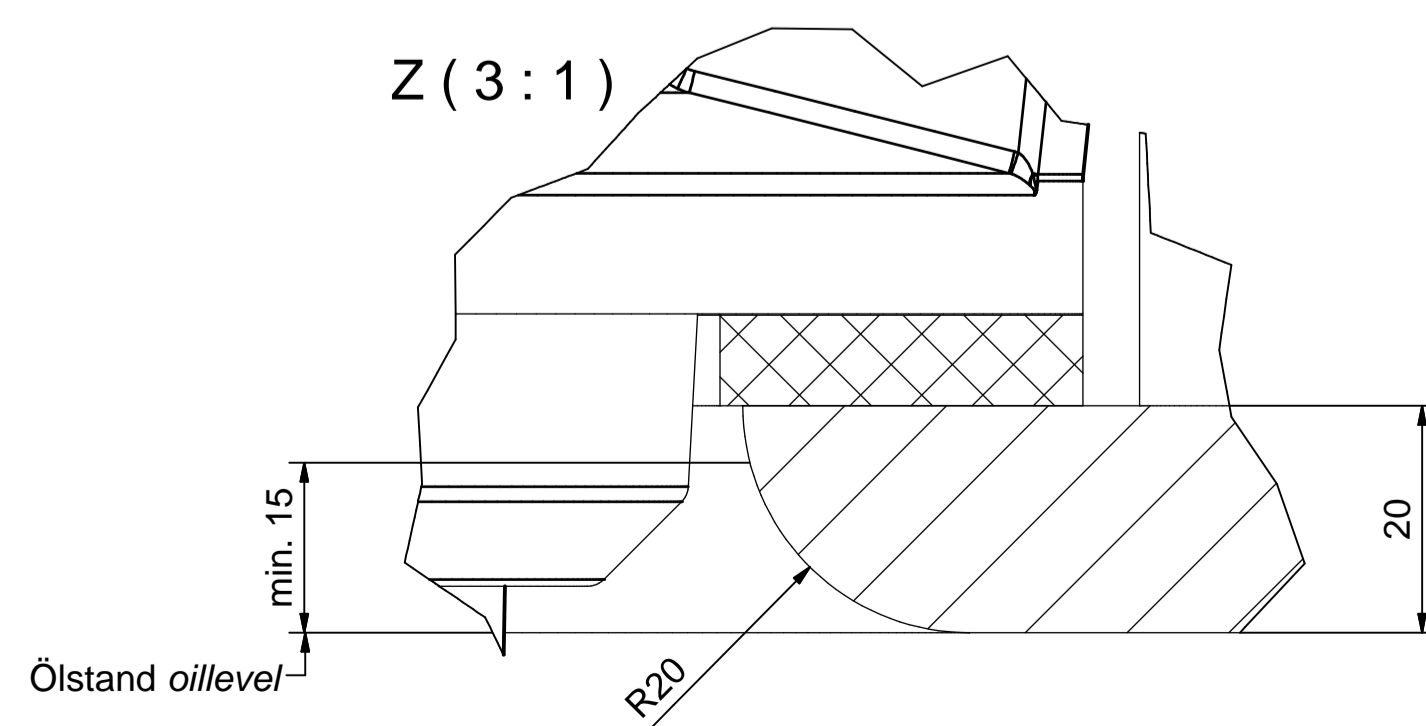

\* nicht im Lieferumfang,  
separat bestellen unter Artikel-Nr.  
827 190-017 (inkl. Muttern und Federringe)  
*not included, must be ordered separately  
with the part number 827 190-017  
(incl. nuts and spring washers)*

| 827 117 168   | 168        | 279                        | 374 | 7,2                        | 36                   |                 |       |  |  |  |  |                           |         |  |  |  |  |              |            |  |  |  |  |                           |        |  |  |  |  |  |  |  |  |  |  |                                |  |             |  |                      |  |            |  |            |  |    |  |                      |  |                            |  |                            |  |          |  |            |  |    |  |  |  |         |  |         |  |
|---|------------|----------------------------|-----|----------------------------|----------------------|-----------------|-------|--|--|--|--|---------------------------|---------|--|--|--|--|--------------|------------|--|--|--|--|---------------------------|--------|--|--|--|--|--|--|--|--|--|--|--------------------------------|--|-------------|--|----------------------|--|------------|--|------------|--|----|--|----------------------|--|----------------------------|--|----------------------------|--|----------|--|------------|--|----|--|--|--|---------|--|---------|--|
| 827 117 107   | 107        | 218                        | 313 | ---                        | 36                   |                 |       |  |  |  |  |                           |         |  |  |  |  |              |            |  |  |  |  |                           |        |  |  |  |  |  |  |  |  |  |  |                                |  |             |  |                      |  |            |  |            |  |    |  |                      |  |                            |  |                            |  |          |  |            |  |    |  |  |  |         |  |         |  |
| 827 117 064   | 64         | 175                        | 270 | ---                        | 36                   |                 |       |  |  |  |  |                           |         |  |  |  |  |              |            |  |  |  |  |                           |        |  |  |  |  |  |  |  |  |  |  |                                |  |             |  |                      |  |            |  |            |  |    |  |                      |  |                            |  |                            |  |          |  |            |  |    |  |  |  |         |  |         |  |
| Nr. / No.   | A          | B                          | C   | Um kV in Luft / in air     | Um kV in Öl / in oil |                 |       |  |  |  |  |                           |         |  |  |  |  |              |            |  |  |  |  |                           |        |  |  |  |  |  |  |  |  |  |  |                                |  |             |  |                      |  |            |  |            |  |    |  |                      |  |                            |  |                            |  |          |  |            |  |    |  |  |  |         |  |         |  |
| <table border="1"> <tr> <td>Maßstab / scale</td> <td colspan="5">1 : 1</td> </tr> <tr> <td>Erstellt von / created by</td> <td colspan="5">Ferenci</td> </tr> <tr> <td>Datum / date</td> <td colspan="5">2007-06-21</td> </tr> <tr> <td>Geprüft von / approved by</td> <td colspan="5">Arranz</td> </tr> <tr> <td colspan="6"> <b>PFISTERER</b><br/>           Pfisterer Kontaktssysteme GmbH Germany         </td> </tr> <tr> <td colspan="2">Erstellt für / replacement for</td> <td colspan="2">Name / name</td> <td colspan="2">Dateiname / filename</td> </tr> <tr> <td colspan="2">Für Kunden</td> <td colspan="2">S02-124526</td> <td colspan="2">A1</td> </tr> <tr> <td colspan="2">Andr. nr. / rev. no.</td> <td colspan="2">And. datum / date of issue</td> <td colspan="2">Dokumentnr. / document no.</td> </tr> <tr> <td colspan="2">20190498</td> <td colspan="2">2019-05-07</td> <td colspan="2">10</td> </tr> <tr> <td colspan="2"></td> <td colspan="2">Ferenci</td> <td colspan="2">827117A</td> </tr> </table> |            |                            |     |                            |                      | Maßstab / scale | 1 : 1 |  |  |  |  | Erstellt von / created by | Ferenci |  |  |  |  | Datum / date | 2007-06-21 |  |  |  |  | Geprüft von / approved by | Arranz |  |  |  |  | <b>PFISTERER</b><br>Pfisterer Kontaktssysteme GmbH Germany |  |  |  |  |  | Erstellt für / replacement for |  | Name / name |  | Dateiname / filename |  | Für Kunden |  | S02-124526 |  | A1 |  | Andr. nr. / rev. no. |  | And. datum / date of issue |  | Dokumentnr. / document no. |  | 20190498 |  | 2019-05-07 |  | 10 |  |  |  | Ferenci |  | 827117A |  |
| Maßstab / scale   | 1 : 1      |                            |     |                            |                      |                 |       |  |  |  |  |                           |         |  |  |  |  |              |            |  |  |  |  |                           |        |  |  |  |  |  |  |  |  |  |  |                                |  |             |  |                      |  |            |  |            |  |    |  |                      |  |                            |  |                            |  |          |  |            |  |    |  |  |  |         |  |         |  |
| Erstellt von / created by   | Ferenci    |                            |     |                            |                      |                 |       |  |  |  |  |                           |         |  |  |  |  |              |            |  |  |  |  |                           |        |  |  |  |  |  |  |  |  |  |  |                                |  |             |  |                      |  |            |  |            |  |    |  |                      |  |                            |  |                            |  |          |  |            |  |    |  |  |  |         |  |         |  |
| Datum / date  | 2007-06-21 |                            |     |                            |                      |                 |       |  |  |  |  |                           |         |  |  |  |  |              |            |  |  |  |  |                           |        |  |  |  |  |  |  |  |  |  |  |                                |  |             |  |                      |  |            |  |            |  |    |  |                      |  |                            |  |                            |  |          |  |            |  |    |  |  |  |         |  |         |  |
| Geprüft von / approved by   | Arranz     |                            |     |                            |                      |                 |       |  |  |  |  |                           |         |  |  |  |  |              |            |  |  |  |  |                           |        |  |  |  |  |  |  |  |  |  |  |                                |  |             |  |                      |  |            |  |            |  |    |  |                      |  |                            |  |                            |  |          |  |            |  |    |  |  |  |         |  |         |  |
| <b>PFISTERER</b><br>Pfisterer Kontaktssysteme GmbH Germany  |            |                            |     |                            |                      |                 |       |  |  |  |  |                           |         |  |  |  |  |              |            |  |  |  |  |                           |        |  |  |  |  |  |  |  |  |  |  |                                |  |             |  |                      |  |            |  |            |  |    |  |                      |  |                            |  |                            |  |          |  |            |  |    |  |  |  |         |  |         |  |
| Erstellt für / replacement for  |            | Name / name                |     | Dateiname / filename       |                      |                 |       |  |  |  |  |                           |         |  |  |  |  |              |            |  |  |  |  |                           |        |  |  |  |  |  |  |  |  |  |  |                                |  |             |  |                      |  |            |  |            |  |    |  |                      |  |                            |  |                            |  |          |  |            |  |    |  |  |  |         |  |         |  |
| Für Kunden  |            | S02-124526                 |     | A1                         |                      |                 |       |  |  |  |  |                           |         |  |  |  |  |              |            |  |  |  |  |                           |        |  |  |  |  |  |  |  |  |  |  |                                |  |             |  |                      |  |            |  |            |  |    |  |                      |  |                            |  |                            |  |          |  |            |  |    |  |  |  |         |  |         |  |
| Andr. nr. / rev. no.  |            | And. datum / date of issue |     | Dokumentnr. / document no. |                      |                 |       |  |  |  |  |                           |         |  |  |  |  |              |            |  |  |  |  |                           |        |  |  |  |  |  |  |  |  |  |  |                                |  |             |  |                      |  |            |  |            |  |    |  |                      |  |                            |  |                            |  |          |  |            |  |    |  |  |  |         |  |         |  |
| 20190498  |            | 2019-05-07                 |     | 10                         |                      |                 |       |  |  |  |  |                           |         |  |  |  |  |              |            |  |  |  |  |                           |        |  |  |  |  |  |  |  |  |  |  |                                |  |             |  |                      |  |            |  |            |  |    |  |                      |  |                            |  |                            |  |          |  |            |  |    |  |  |  |         |  |         |  |
|   |            | Ferenci                    |     | 827117A                    |                      |                 |       |  |  |  |  |                           |         |  |  |  |  |              |            |  |  |  |  |                           |        |  |  |  |  |  |  |  |  |  |  |                                |  |             |  |                      |  |            |  |            |  |    |  |                      |  |                            |  |                            |  |          |  |            |  |    |  |  |  |         |  |         |  |