

Alle Längenangaben wenn nicht anders angegeben in mm
 Measures in mm if not mentioned otherwise.

Dichtfläche Buchse $\sqrt{Ra\ 1,6}$, $\sqrt{Rz\ 6,3}$, $\sqrt{Rt\ 6,3}$
 lackiert mit 2K PU-Lack
 Sealing Surface socket
 coated with 2K PU-varnish

1 Dichtfläche $\sqrt{Ra\ 1,6}$, $\sqrt{Rz\ 6,3}$, $\sqrt{Rt\ 6,3}$
 Sealing Surface

Dichtsystem im Lieferumfang des
 Trafo- Herstellers
 Sealing system in scope of supply
 of the transformer manufacturer

2 Teilkreisdurchmesser für 16x Zylinderschraube M12x70
 Pitch circle diameter for 16x cylinder head screw M12x70

3 Kapazitiver Spannungsabgriff optional
 Kapazität bei eingestecktem Kabel 3pF; Toleranz ±3%
 capacitive voltage tap optional
 Capacity with plugged cable 3pF; Tolerance ±3%

Nr. / No.	Kapazitiver Spannungsabgriff capacitive voltage tap	16x M12x70
828 071 999-00006	ja / yes	ja / yes

Maße entsprechen EN 50299-1:2014 Bild 2 (Trafo)
 Dimensions according to EN 50299-1:2014 Fig. 2 (Trafo)

weitere Angaben siehe Montageanleitung
 further details see assembly instructions

Gewinde / Thread	Drehmoment / Torque
M10	ca. 35 Nm
M12	ca. 45 Nm
M16	ca. 50 Nm

Maßstab / scale 1 : 2,5	Gewicht ca. / weight ca. (g) 45000	Beschreibung / title HV-CONNEX Geräteanschlusssteil Gr. 7/7-S für ölisierte Anlagen, Variantenartikel HV-CONNEX socket size 7/7-S for oil insulated equipment, variant article			
Erstellt von created by Ferenci	Datum / date 2017-04-13	Dokumentart / type of document Für Kunden			
Geprüft von approved by Arranzp	Datum / date 2017-04-13	Dateiname / filename S02-168415			
PFISTERER PFISTERER Kontaktsysteme GmbH Germany		And. nr. / rev. no. 2018-08-22	Name / name Ferenci	Index / rev 02	Blatt / sheet 1/1 828071999A6

Bedingungen / Conditions	Stückprüfung für Um=300kV routine test for Um=300kV
Wechselspannung / AC voltage	505 kV AC, 1 min
Teilentladung / partial discharge	460 kV AC, < 5 pC

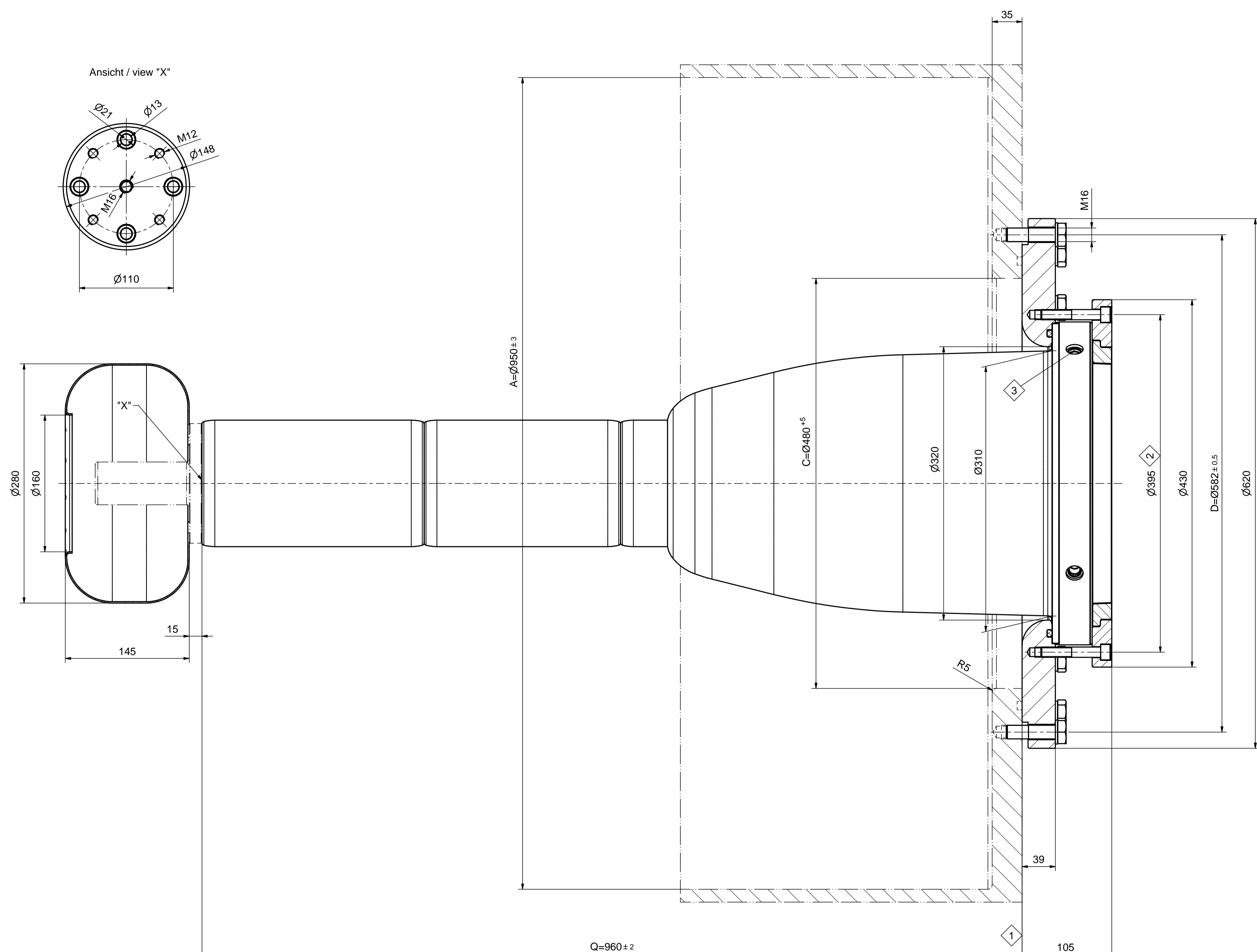

The reproduction, distribution and utilization of this document as well as the communication of its contents to third parties without the prior written consent of the manufacturer is prohibited. Offenders will be held liable for the payment of damages. All rights reserved in the event of the violation of the above-mentioned provisions.