

Weitergabe sowie Vervielfältigung dieses Dokuments, Verwertung und Mitteilung seines Inhalts sind verboten, soweit nicht ausdrücklich gestattet. Zuwiderhandlungen verpflichten zu Schadensersatz. Alle Rechte für den Fall der Patent-, Gebrauchsmuster- oder Geschmacksustereintragung vorbehalten. © Pfisterer

The reproduction, distribution and utilization of this document as well as the communication of its contents to others without explicit authorization is prohibited. Offenders will be held liable for the payment of damages. All rights reserved in the event of the grant of a patent, utility model or design. © Pfisterer

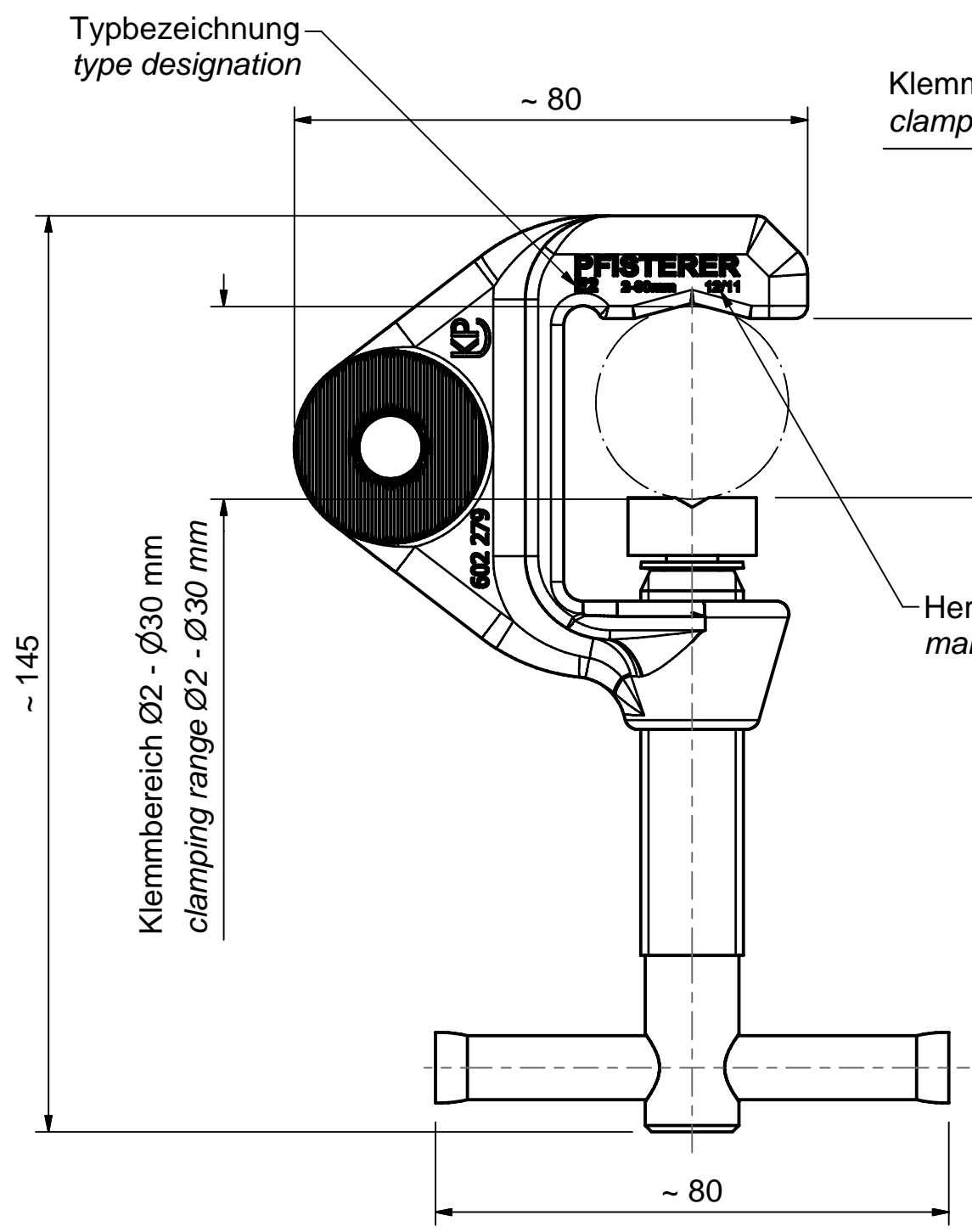
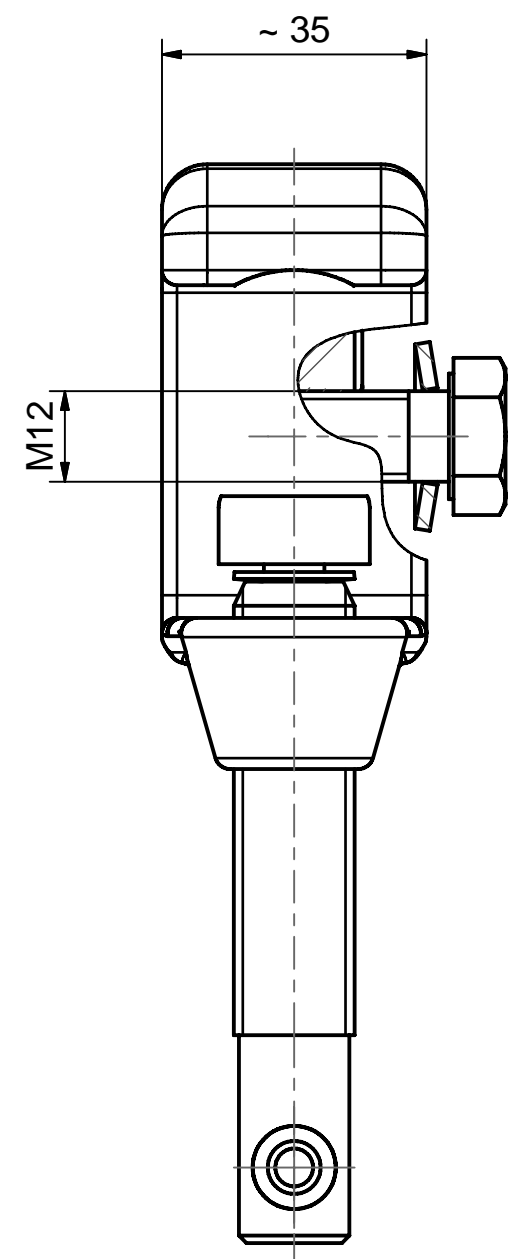

Klemmbereich 2 - 30 mm  
clamping range 2 - 30 mm

Herstelldatum Monat/Jahr  
manufacturing date month/year

Typbezeichnung  
type designation

Klemmbereich Ø2 - Ø30 mm  
clamping range Ø2 - Ø30 mm

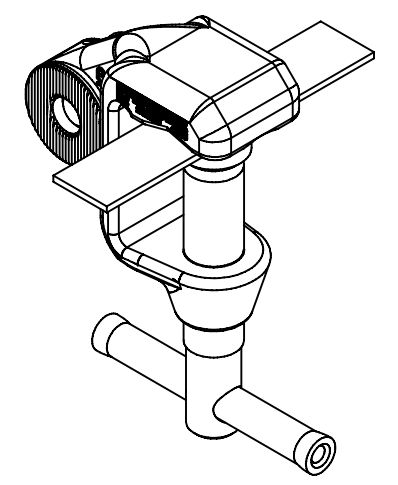
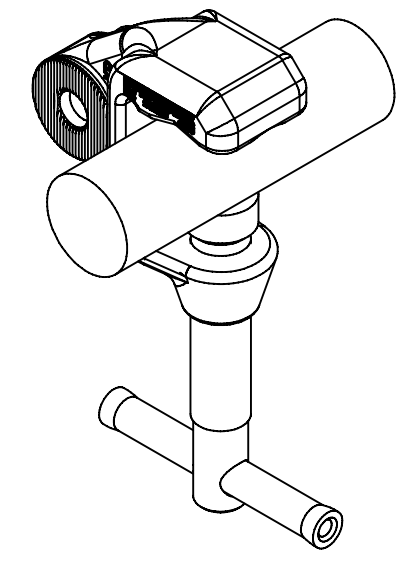

Maßstab / scale 1 : 1		Gewicht ca. / weight ca. (g) 368											
Name / name Leissner		Datum / date 2006-03-22		Beschreibung / title Erdanschlussklemme E2 2-30 mm, Schraubknebel									
Erstellt von created by Wienbrack		Geprüft von approved by 2006-03-22		Earth connection clamp E2 2-30 mm, with capstan-head screw									
<b>PFISTERER</b> Kontaktsysteme GmbH				Ersatz für / replacement for		Dokumentart / type of document Für Kunden		Dateiname / filename S03-121284		Format / size A3		Blatt / sh. 1/1	
				Änd.nr. / rev. no. 20110998		Änd.datum / date of issue 2011-12-19		Name / name Fragner		Index / rev. 02		Dokumentnr. / document no. <b>360419004A</b>	