

Weitergabe sowie Vervielfältigung dieses Dokuments, Verwertung und Mitteilung seines Inhalts sind verboten, soweit nicht ausdrücklich gestattet. Zuwiderhandlungen verpflichten zu Schadensersatz. Alle Rechte für den Fall der Patent-, Gebrauchsmuster- oder Geschmacksustereintragung vorbehalten. © Pfisterer

The reproduction, distribution and utilization of this document as well as the communication of its contents to others without explicit authorization is prohibited. Offenders will be held liable for the payment of damages. All rights reserved in the event of the grant of a patent, utility model or design. © Pfisterer

Druckschraube M26x1,5 SW8
pressure screw M26x1,5
widht across flats 8

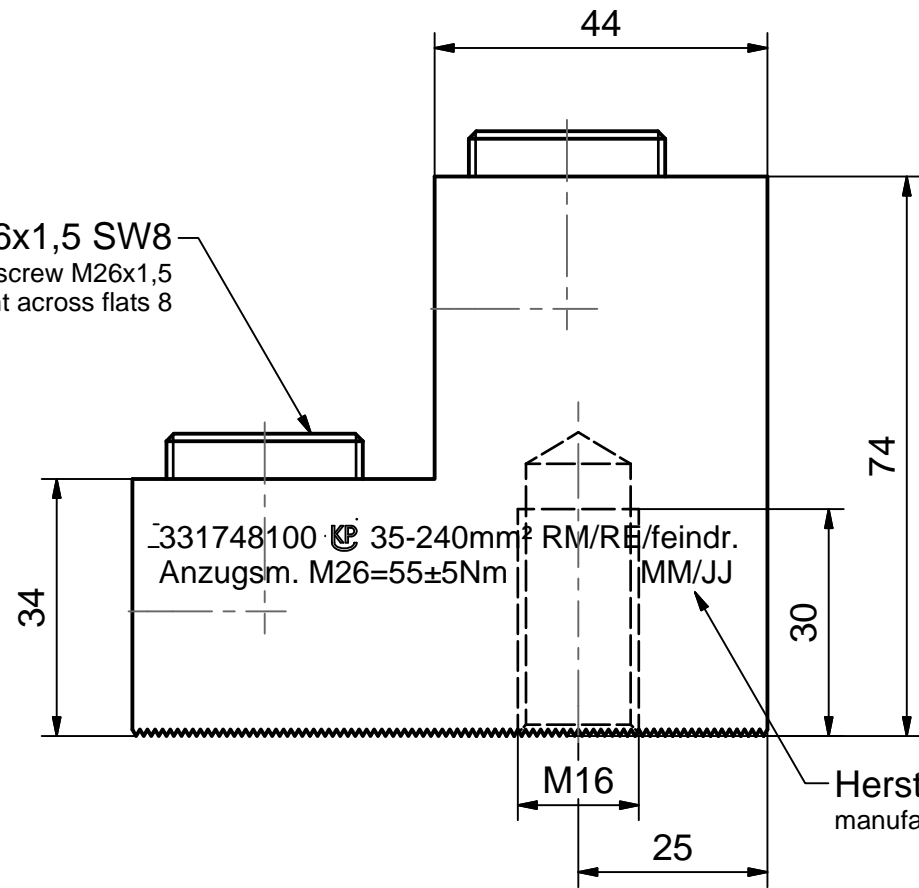

Herstelldatum Monat/Jahr
manufacturing date month/year

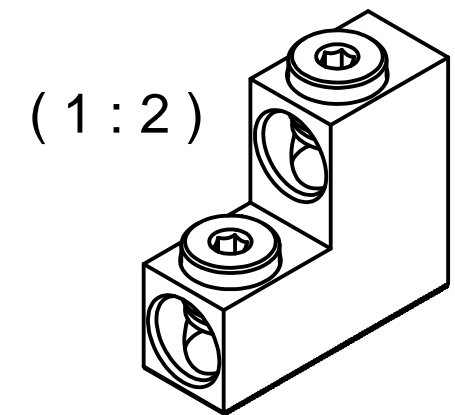
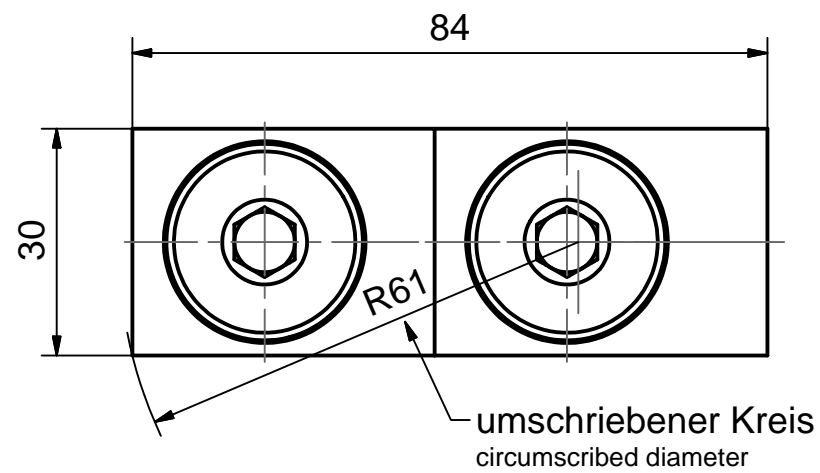
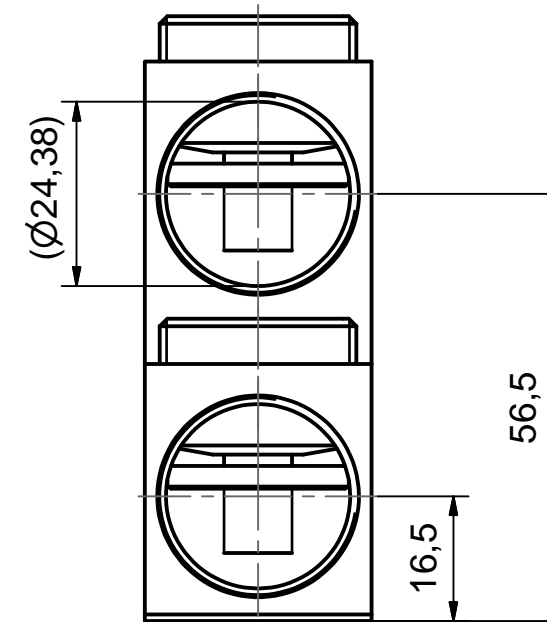

Maßstab / scale	Gewicht ca. / weight ca. (g)		Beschreibung / title				
1 : 1	395						Stromanschlussklemme 2D-A, 35-240mm ² Zweileiter für Durchführung M16 Current terminal clamp 2D-A, 35-240mm ² 2core for terminal M16
	Name / name	Datum / date	Ersatz für / replacement for				
Erstellt von created by	Patzschke	2009-02-23					Dokumentart / type of document Für Kunden
Geprüft von approved by	Leissner	2009-02-27	Dateiname / filename S03-133820		Format / size A3	Blatt / sh. 1/1	
PFISTERER Kontaktsysteme GmbH & Co. KG			Änd.nr. / rev. no. 20110801	Änd.datum / date of issue 2011-11-16	Name / name Deutinger	Index / rev. 04	Dokumentnr. / document no. 331748100A